

# **REMOTE ENGINE STARTER SYSTEM**

**FOR MANUAL OR AUTOMATIC VEHICLES**

***INSTALLATION MANUAL***

# WIRING DESCRIPTION

## 6 WIRE CONNECTOR (14 GAUGE WIRE)

<b>RED</b>	12V constant wire (12V positive input) connect to a 12V constant, 30A fuse built-in
<b>RED</b>	12V constant wire (12V positive input) connect to a 12V constant, 30A fuse built-in
<b>GREEN</b>	Auxiliary 12V positive output for 2 <sup>nd</sup> ignition, 2 <sup>nd</sup> accessory, 2 <sup>nd</sup> starter, 20A fuse built-in (see option # 5)
<b>ORANGE</b>	Accessories wire (12V positive output) connect to accessory wire that controls the heater/air conditioning fan
<b>YELLOW</b>	Starter wire (12V positive output) connect to starter wire
<b>BLUE</b>	Ignition wire (12V positive output) connect to main ignition

## 20 WIRE CONNECTOR (20 GAUGE WIRE)

<b>WHITE</b>	Brake wire (12V positive input) connect to the switched side of the brake pedal switch
<b>YELLOW / BLUE</b>	OUTPUT #1 (500mA negative output) give a pulse to disarm the factory alarm
<b>RED / WHITE</b>	Horn or siren wire (500mA negative output) connects to horn or siren. Require a relay if siren is used
<b>WHITE / BLACK</b>	Starter kill disable wire (500mA negative output) connect to starter kill relay. Can be programmed for 2 <sup>nd</sup> slide-door (see option #7, only for 2way FM system)
<b>YELLOW / RED</b>	500mA negative starter output
<b>PINK</b>	OUTPUT #3: 500mA negative output. It can give a pulse to rearm factory alarm or open Sliding Door or Transponder Bypass (see option # 9)
<b>BROWN</b>	Hood wire (negative input) connect to hood pin switch

# WIRING DESCRIPTION

## 20 WIRES CONNECTOR (20 GAUGE WIRE)

<b>GREEN / BLACK</b>	OUTPUT# 4: 500mA negative output for trunk opener
<b>PURPLE</b>	TACH wire (AC input) connect to TACH signal wire (coil or injector or alternator DC voltage)
<b>GREEN / YELLOW</b>	Negative parking light 500mA
<b>WHITE / GREEN</b>	Unlock wire (500mA negative output) See central door lock connection diagram
<b>WHITE / RED</b>	Lock wire (500mA negative output) See central door lock connection diagram
<b>WHITE / BLUE</b>	Door trigger positive input, connect to positive door switch
<b>BLUE</b>	Hand brake wire (negative input) connect to the switched side of hand brake switch (for vehicle with manual transmission only)
<b>YELLOW</b>	OUTPUT #2: 500mA constant negative
<b>ORANGE</b>	500mA negative accessory output
<b>BLUE / WHITE</b>	Door trigger negative input, connect to negative door switch
<b>BLUE / RED</b>	500mA negative ignition output
<b>LIGHT GREEN</b>	Parking lights Positive output, 15A fuse built in
<b>BLACK</b>	Ground wire, <i>Important</i> connect to a proper ground

# WIRING DIAGRAM

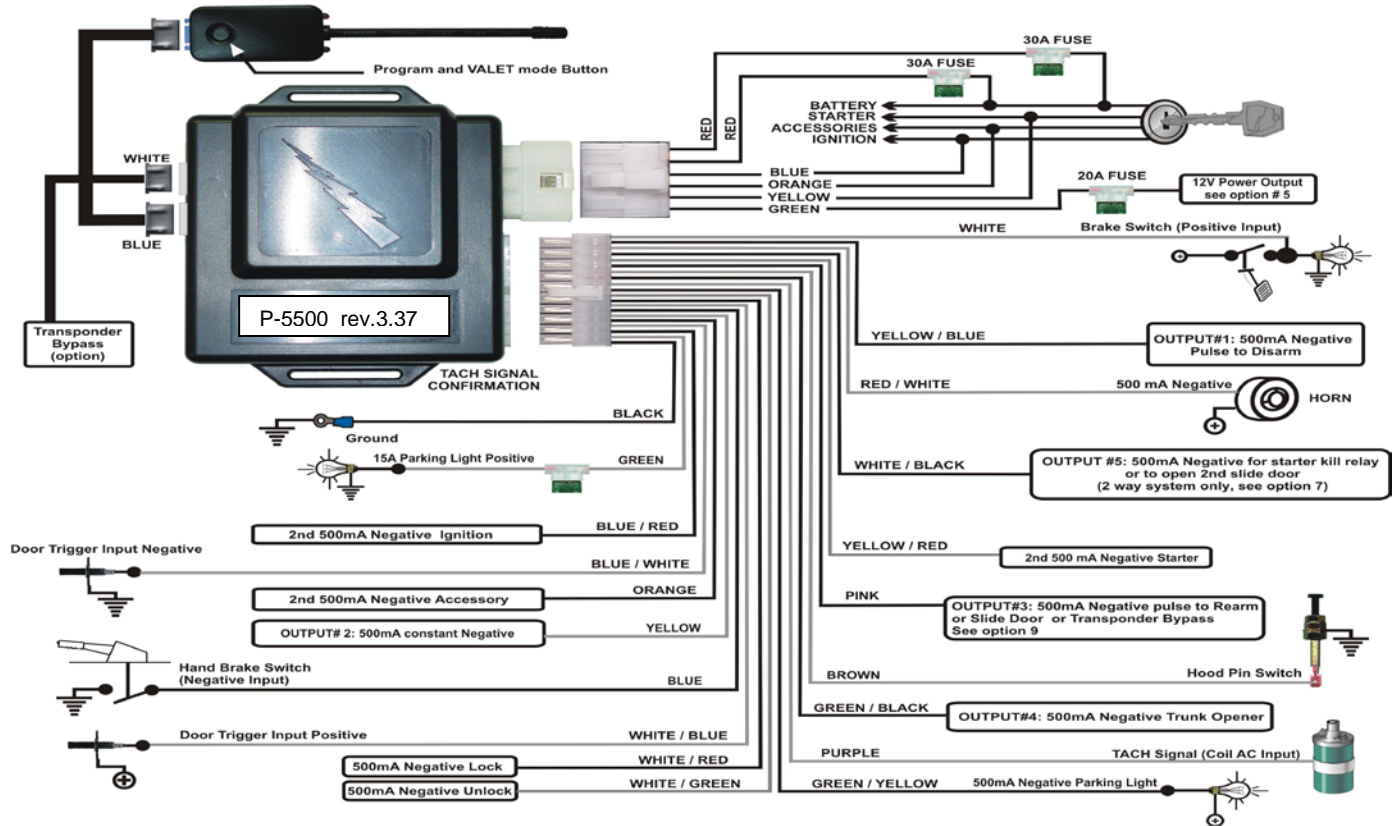

# CENTRAL DOOR LOCK CONNECTION

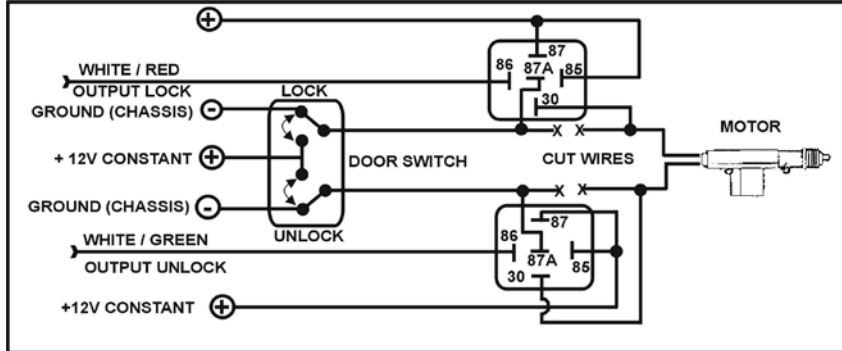

**DIAGRAM 1:  
REVERSE POLARITY TYPE**

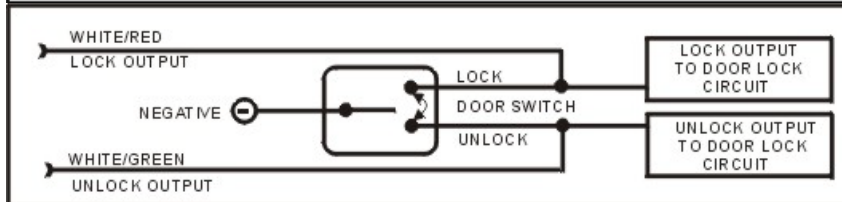

**DIAGRAM 2:  
NEGATIVE TYPE**

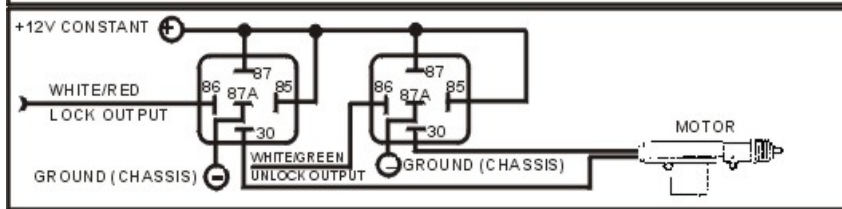

**DIAGRAM 3:  
ADDING DOOR LOCK ACTUATOR**

# PROGRAMMING





Our remote starter is delivered with factory default settings. You can install it without programming or you can modify the configuration to suit your customer's need. **Important: the installation must be completed before accessing programming mode.**

## **Programming the system:**



1. Turn the ignition 3 times OFF to ON and leave the key in the ON position (engine not running).
2. Within 15 seconds, push 1 time on the antenna button. You will hear 5 beeps to confirm that the system is now in programming mode. The L.E.D. built-in receiver will flash slowly.

**Note:** If the 15 seconds delay has expired, just turn the ignition OFF and repeat steps 1 and 2.

The system has **20 programmable options** and there are 1 to 3 different possibilities to modify.



- Step 1** Press then release antenna button to select option 1 to 20 (depend on models, see programming chart). Every time you press on receiver button you will hear one beep. Count the beep to reach desired option.
- Step 2** When you have reached the desired option depress brake pedal to confirm.
- Step 3** Press button ,  or \* on transmitter to choose between different possibilities (  to select column 1, you will hear 1 beep,  to select column 2, you will hear 2 beeps or \* to select column 3, you will hear 3 beeps). Depress brake pedal again and count the beep to confirm that the feature has been changed.
- Note: if you have more than one option to modify, repeat steps 1 to 3.**
- Step 4** When finished, Turn ignition OFF to exit programming mode. One long beep will be emitted.

# PROGRAMMING CHART

OPTION	FUNCTION	PRESS  BUTTON TO:	PRESS  BUTTON TO:	PRESS * BUTTON TO:
1A	TACH Learning <b>See example: #3</b>	Learn		
1B	TACH fine tuning <b>See example # 4</b>	Increase	Decrease	
2	Cranking adjustment	◆ Normal	Slight increase	Increase
3	Audible Arming/Disarming	Enable	◆ Disable	
4	Running time Duration	10 minutes	◆ 15 minutes	25 minutes
5	Auxiliary output	◆ 2 <sup>nd</sup> ignition	2 <sup>nd</sup> accessory	2 <sup>nd</sup> starter
6	Glow plug waiting time before starting	◆ 0 second	10 seconds	20 seconds
7	White/Black: Output # 5 select	◆ Starter kill	Tachless mode with Starter kill	“Push start” mode
8	Night timer mode	Starts engine every 2 hours	◆ Starts engine every 3hours	Starts engine every 4 hours
9	Pink: Output # 3 Select	◆ Rearm Pulse	Slide Door Opener (  2sec)	Transponder bypass
10	Door lock Signals	◆ 0.5 second	1.2 seconds	Unlock double pulses
11	Ignition lock	◆ Disable	Enable	
12	Passive lock	Enable	◆ Disable	L.E.D. OFF
13	Starter kill/Alarm Arming See example #1	◆ Passive arming	Active arming	
14	Sequence mode (For manual vehicle only)	You do not need to press on any button of your transmitter to enter the reservation mode	◆ Press * button of transmitter each time you want to enter into the sequence mode	

◆ Factory default setting

# PROGRAMMING CHART

<b>15</b>	Horn/Siren	◆ Horn	Siren	
<b>16</b>	Dome light delay	◆ Disable	Enable & Doors Bypass for 45 seconds when engine shut-off	
<b>17</b>	Hood pin polarity	◆ Active in low level	Active in high level	
<b>18</b>	Door Lock/Unlock configuration	◆ Normal	Unlock before start Lock after start Lock after shut down	Lock only after remote start shut down
<b>19</b>	Factory default setting <b>See example #5</b>	Press button  to reinitialize 4 beeps confirmation will be emitted		
<b>20</b>	Transmitter code learning. See example # 2	Press button  until 4 chirps confirmation		

◆ Factory default setting

## VALET MODE:

Turn the ignition key to ON position (engine not running). Push and hold the receiver button for 5 seconds to enter into valet mode. The system will chirp 3 times and the receiver's L.E.D. will stay solid. When the system is in the valet mode, you can not remote start (parking light will flash 2 times when you try remote start).

To remove valet mode, repeat the same operation. The system will chirp 1 time and the receiver L.E.D. will turn OFF.



# PROGRAMMING OPTIONS

## **OPTION 1A: TACH LEARNING ( SEE EXAMPLE #3 )**

The factory default setting should normally adapt to most vehicles on the market. After the installation is completed, start engine with transmitter and most of the time you will have a perfect start. If the starter motor is over crank or release too fast, you must process with the TACH learning option or manual fine-tuning.

## **OPTION 1B: TACH FINE TUNING ( SEE EXAMPLE #4 )**

Occasionally with factory default setting or TACH learning feature you might not reach the exact performance. This option allows you to fine-tuning the TACH signal manually.

When this option is set for 10 beeps, the system will detect alternator DC voltage as valid Tachometer.

## **OPTION 2: CRANKING ADJUSTMENT**

If you expect that the vehicle needs adjusting you can force the starter to slightly under crank or over crank. This adjustment may be necessary in some older vehicles or vehicles with diesel engines to help the engine start in extremely cold weather conditions.

## **OPTION 3: AUDIBLE ARMING / DISARMING**

When this option is enabled, the system will chirp every time when system arms or disarms.

## **OPTION 4: RUNNING TIME DURATION**

This option allows you to set the remote start engine running time for 10, 15 or 25 minutes. When remote started, the engine will run for the selected amount of time.

## **OPTION 5: POWER AUXILIARY OUTPUT**

This option allows you to set the AUXILIARY OUTPUT as:

**1**: 2<sup>nd</sup> ignition

**2**: 2<sup>nd</sup> accessory

**3**: 2<sup>nd</sup> starter

# PROGRAMMING OPTIONS

## **OPTION 6: GLOW PLUG WAITING TIME ( FOR DIESEL ENGINE )**

Diesel engines need to warm up glow plugs before starting. Turn ignition key ON and count how many seconds it takes for the glow plug light to turn OFF then select the closest waiting time.

## **OPTION 7:OUTPUT # 5**

1. Starter kill
2. 2<sup>nd</sup> Sliding door opened: press  button for 2 seconds to open sliding door.(2 way system only)

## **OPTION 8: NIGHT TIMER MODE**

The system will start engine by itself and will run for 6 minutes every 2, 3 or 4 hours for a maximum 4 times. This feature is highly appreciated when very cold nights are forecast. To access night timer mode: Keep pressing “\*” button for 2 seconds, the parking light will flash 4 times.

## **OPTION 9: OUTPUT # 3 CAN BE PROGRAMMED AS**

1. Factory Alarm Rearm
2. Sliding door opened: press **AUX** button for 2 seconds to open sliding door.
3. Transponder bypass (output release upon accessory turn on).

## **OPTION 10: DOOR LOCK SIGNAL TIMING**

1. Lock or unlock: pulse for 0.5 second
2. Lock or unlock: pulse for 3 seconds
3. Unlock: 2 pulses, the first pulse to open the driver door, the second for all passenger doors

# PROGRAMMING OPTIONS

## **OPTION 11: IGNITION LOCK**

This feature allows the system to lock all doors when ignition key is ON. By depressing the brake pedal, all doors will unlock automatically when ignition key is OFF.

## **OPTION 12: PASSIVE LOCK**

Passive lock works only when passive arming option is enable (see option #13). Passive lock allows the system to lock all doors when armed. If this option is disabled, all the doors will lock only when system is armed by transmitter. However, if this option is programmed for L.E.D. OFF, the L.E.D. on the antenna will be OFF permanently even when the system is armed.

## **OPTION 13: PASSIVE OR ACTIVE ARMING (SEE EXAMPLE # 1)**

1. Passive arming arms the starter kill / alarm 30 seconds after the ignition is OFF, hood is closed.
2. Active arming arms the starter kill / alarm only by remote transmitter.

## **OPTION 14: FOR MANUAL TRANSMISSION VEHICLE ONLY**

You can choose with or without transmitter to program exit sequence (reservation mode). When without transmitter sequence is selected, it does not require pressing \* button each time you perform an exit sequence.

## **OPTION 15: VEHICLE HORN OR SIREN**

Horn will give a 500mA negative ground pulse signal when Alarm or Panic is triggered. When Siren option is selected, the system will give a 500mA negative ground constant. We recommend using the relay for siren if installed.

# PROGRAMMING OPTIONS

## **OPTION 16: DOME LIGHT DELAY**

If the vehicle comes with dome light delay, it is important to enable this option. Otherwise, the start sequence for manual transmission only may be lost. ***Note: When dome light delay mode is selected, the parking lights will flash 3 times when arms the system.***

## **OPTION 17: FAST UNLOCK DOOR (2 WAY ONLY)**

This option is used to reduce unlock door response time.

## **OPTION 18: DOOR LOCK / UNLOCK CONFIGURATION**

In some vehicles the doors unlock when the remote starting the car. Use this option to overpass this problem.

## **OPTION 19: FACTORY DEFAULT SETTING (SEE EXAMPLE # 5)**

This option allows you to reinitialize the system back to factory default settings in case of confusion or when you reinstall the system in another vehicle and you do not want to keep the old setting.

## **OPTION 20: TRANSMITTER CODE LEARNING (SEE EXAMPLE # 2)**

This option allows you to add or learn the new transmitter into your system. You can program up to 4 different transmitters.



# PROGRAMMING EXAMPLES

## EXAMPLE 1, OPTION 13: CHANGE FROM PASSIVE ARMING TO ACTIVE ARMING

Option 13, default setting is passive arming. System will arm automatically after ignition key is OFF for 30 seconds delay. You want to change to active arming.

1. Access programming mode (see programming procedure).
2. Press and release program button 13 times and count 13 beeps.
3. Depress brake pedal to confirm. You should hear 1, 2 or 3 beeps to confirm which option is currently programmed.

**Note:** If you hear 1 beep, it means current option is passive arming.  
If you hear 2 beeps, it means current option is active arming with safety rearm.

4. Press on transmitter to change option:
  - Button  for passive arming, you will hear 1 beep.
  - Button  for active arming, you will hear 2 beeps.
5. Turn ignition OFF to exit programming mode.

# PROGRAMMING EXAMPLES

## EXAMPLE 2, OPTION 20: TRANSMITTER CODE LEARNING

The transmitter supplied is already programmed to the system. This option allows you to add more transmitters to your system if needed.

1. Access programming mode (see programming procedure).
2. Press and release program button 20 times and count 20 beeps.
3. Depress brake pedal to confirm.
4. Press button  on the transmitter. You will hear 5 beeps. The new transmitter code is learned. If you press on the same transmitter 4 times, all another previously stored transmitter codes in the system will be erased.
5. Turn ignition OFF to exit programming mode.

## EXAMPLE 3, OPTION 1A: TACH LEARNING

The factory default setting should normally operate with most vehicles on the market. Note that some vehicles equipped with multi coil system have a very low TACH signal. In that case, the TACH learning feature will allow the system to adjust itself to the TACH signal of the vehicle.

***Important note: engine must be warm and at idle speed (approximately 800 rpm) before proceeding with TACH learning, otherwise preheat engine for at least 10 minutes before processing.***

1. Access programming mode (see programming procedure).
2. Press then release the antenna button 1 time and count 1 beep.
3. Depress brake pedal to confirm, you should hear 3 beeps, (factory default setting) Blue L.E.D. will flash rapidly.
4. Start the engine and wait for the lowest idle.
5. Press button  on the transmitter, you should hear 1 beep, TACH signal has been learned.
6. Turn ignition OFF to exit programming mode.

# PROGRAMMING EXAMPLES

## **EXAMPLE 4, OPTION 1B: FINE TUNING THE TACH SIGNAL**

Even with the factory TACH default setting or TACH learning features you can not reach the exact setting; *example: idle is too high*. This option will allow you to fine tune the TACH signal manually; make sure the engine is *not running*.

1. Access programming mode (see programming procedure).
2. Press then release the antenna button 1 time and count 1 beep.
3. Depress brake pedal, you should hear 3 beeps (factory default setting) You must count the number of beeps, minimum 1 beep and maximum 9 beeps. If 9 beeps is selected the TACH signal will be sensed as DC voltage rather than AC signal. If you miss the number of beeps, depress brake pedal again to count the beeps. Blue L.E.D built-in receiver will flash rapidly.

**Note:** At this step, you must carefully count the number of beeps when you depress brake pedal, in order to increase or decrease TACH signal level, decrease when TACH signal is weak and increase when TACH signal is strong.

**Example:** *you start the engine via the transmitter, if the starter motor is over cranking decrease the signal level. If the starter motor release too fast, increase the signal level.*

4. Press button  on the transmitter to increase signal level or press button  to decrease signal level.

# PROGRAMMING EXAMPLES

## **EXAMPLE 5, OPTION 19: REINITIALIZE TO FACTORY DEFAULT SETTING**

In case of confusion or you want to install the system in another vehicle and you don't want to keep the old settings. The option 19 allows resetting of the system back to factory default setting.

1. Access programming mode (see programming procedure).
2. Press and release program button 19 times and count 19 beeps.
3. Depress brake pedal to confirm.
4. Press button  on the transmitter, you will hear 1 beep. Factory default setting is reinitialized.
5. Turn ignition OFF to exit programming mode.



# REMOTE ENGINE STARTER DIAGNOSTIC

## DIAGNOSTIC FOR REMOTE STARTER:

Each time you try to remote start the vehicle and it doesn't start, the parking lights will flash to indicate the reason why.

1 Flash:	Brake pedal depressed
2 Flashes:	Valet mode ON
3 Flashes:	Hood opened
4 Flashes:	Shut down via transmitter
5 Flashes:	Not used
6 Flashes:	Running time expired
7 Flashes:	Cranking time expired, engine not running
8 Flashes:	Exit sequence cancelled (manual transmission only)
9 Flashes:	TACH wire disconnected
10 Flashes:	Hand brake not pulled (manual transmission only)
11 Flashes:	Door opened (manual transmission only)
12 Flashes:	Ignition is ON when start via remote

# LIMITED WARRANTY

The manufacturer guarantees to the purchaser of origin the remote starter and alarm to be free of defect material and labour. However, if it is proven that the product is defective, inside the two year period as from the original date of purchase, the manufacturer will repair or replace, without expenses towards the purchaser, any part (excluding any expenses incurred to deliver the product to the manufacturer) remote starter or alarm which the manufacturer considers defective. After the initial warranty period of 2 years, the manufacturer must repair or replace the defective products with a forwarding costs of 30.00\$US. All the guarantees apply to the original purchaser and ONLY to the vehicle in which it is initially installed. Repairs or replacement of the defective modules must remain at the discretion of the manufacturer. All the other parts, components, accessories or optional equipment relating to the remote starter and alarm are not included in the guarantee of the manufacturer. This guarantee is nontransferable. The original receipt must accompany a request for guarantee of service of any authorized retailer in factory. The fact of not conforming to these conditions can result in cancellation of the guarantee.

This guarantee does not cover the following elements: expenses for labour of removal or reinstallation, transport charges, abuse, misuse or accidental damage of the remote starter and the alarm or parts of the latter. This guarantee is cancelled in the event of amendments, repairs or deteriorations of any part of the product. The manufacturer does not guarantee or does not insure against the loss of the vehicle or its contents. The models of alarm are used only as dissuasion against any possible loss. This alarm can be considered for a reduction of the insurances; premiums please contact your insurance agent for more details. The manufacturer should not be held responsible for any consequent damage connected to a violation of this or any other guarantee express or implicit. This guarantee gives you specific statutory duties. These rights vary according to the area in which you reside.

**CERTAIN DAMAGE IS EXCLUDED.** The manufacturer declines any responsibility for additional damage caused by the product, including a financial loss, loss of use of the product, hiring of vehicle or all other expenses connected to the maintenance and the guard of the product. The manufacturer declines any responsibility for any additional damage caused by the product or resulting from his use, including the expenses of repair or replacement of other goods damaged or caused by his use, even if the product functions correctly. This product is designed to dissuade from an unauthorized use of the vehicles in which it is installed. The manufacturer does not guarantee that the product is proof against loss and vandalism and the human error or an inadequate use. The manufacturer does not accept any responsibility for any damage occurring any kind that it is caused by a vehicle in which the product is installed or resulting from damage from its use. The manufacturer does not accept any responsibility for any damage resulting from the loss of the vehicle or its contents, caused or claimed caused, directly or indirectly, by a failure of the product.

**STARTER WITH MANUAL SHIFT** – the installation of a remote starter **MUST** be carried out with an indicated manual transmission remote starter. It is the sole responsibility of the operator of the vehicle to make sure that the vehicle is left with the transmission in neutral when the remote starter is used. The manual transmission remote starter is designed as supplementary measure of safety **ONLY!** The manufacturer does not guarantee or does not insure against any damage or loss of life, which can result from remote starting the remote starter when the vehicle is in gear. The models for manual transmission are only designed to act as a preventive measure against starting in gear; it remains the sole responsibility of the operator or the owner of the vehicle to make sure the transmission is in neutral.